JIELI

WHEEL LOADER ZL15





QINGZHOU JEILI MACHINERY CO.,LTD

**ADDRESS: NO. 266 YINGZHOU ROAD, NAOSHAN ECONOMIC DEVELOPMENT ZONE,
SHAOZHUANG TOWN, WEIFANG CITY, SHANDONG ,PROVINCE , CHINA**

Mobile :+8615265652947

What's app:+8615265652947

Email :lilysong@qzjeli.com

Website:www.qzjeli.com

WHEEL LOADER ZL15

Advantage

1) Maximum traction through articulated pendulum joint

- With the articulated pendulum joint, all four wheels maintain traction even on uneven terrain. This increases the productivity of the machine and gives the driver optimal control.

The optimal ratio of articulation and oscillation angle ensures a high level of grip on the ground. This makes the machine easy to maneuver.

Even in confined spaces, there is no collision between the front and rear of the machine.

- The front and rear sections can swing independently of each other. This allows the driver to react sensitively to any unevenness. This increases comfort and creates a safe driving experience

2) Compact size and optimal driveability, because of the special articulated pendulum joint, it has a very good turning angle, so it is most suitable for operation in a narrow space to exert its maximum value

3) The articulated pendulum joint is made of Cast iron, more fashionable and protects the machine from crash

4) Heating chair with airbag, it provides different demands for customers, if the customers are especially those living

in Nordic countries, like Denmark, Norway, Sweden, Finland and Iceland, you can choose it, others choose the standard one is ok

5)Iron cast counterweight ,looks more neo-modern,It makes the appearance of the entire vehicle have higher aesthetic value and visual enjoyment, to attract more customers' attention and provide more added value for customers(option configuration)

Standard Configuration

bigger cabin or small cabin, new type engine hood, Xinchai 498 EURO3 engine,36.8kw,20.5/70-16 tire, level standard bucket(0.8m³) with floating function, 0.8m³ bucket, drum brake, adjustable steering wheel, standard seat, preheating + heater for cabin, LED lamp on cabin, waterproof plug-in, back sound, radio, fan, extinguisher, window hammer, engine heater 220V, 3- way mechanic joystick, quick hitch, rear camera, unloading height is 2700mm ,lifting capacity 1500kgs/1800KGS (If with iron cast rear counterweight) , lifting capacity 1800kgs ,operation weight 4000kgs ,Free service spare parts

Standard Configuration

23.5/70-16 tire, winter tire, A/C, loading dumper, center , iron cast rear counterweight, Yunei EURO5 ,Yuchai EURO 5,Yarman Euro5,Cummins EPA4,multifunction attachments ETC

Technical Parameter

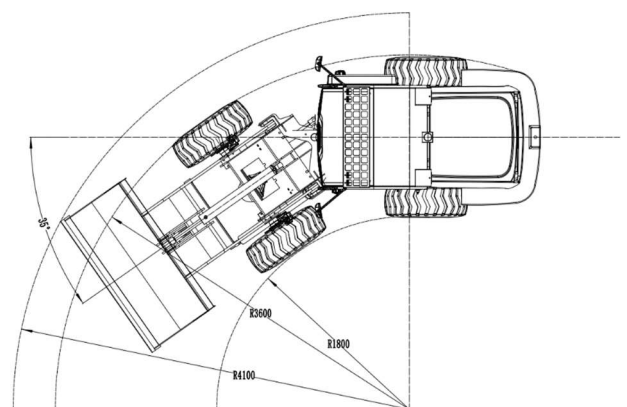
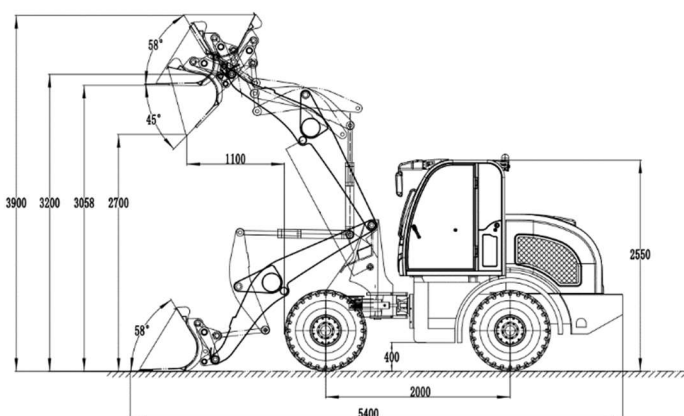

Bucket capacity 0.8m³

Loading capacity1500kgs

Max driving Speed 30km/h

Net weight 4200kgs

Dump height 2800mm

minimum turning radius (outside of wheels) 4400mm

Tire 20.5/70-16

service braked drum-brake, Air-assist hydraulic brake, disc brake

QINGZHOU JIELI MACHINERY CO.,LTD